

# Expanding Indian Microfinance Through Integrative Technology



Jill Fioravanti

Ann Le

Rajesh Sharma

Yumna Siddiqi

# Agenda

- Introduction & History
- Overview: Microfinance in India
- Critical Needs
- Industry-wide Technology Solution
- Challenges
- Q & A

# Introduction

- UCLA Anderson
- Oracle
- Project Goals
- Research Methodology



# Microfinance In India

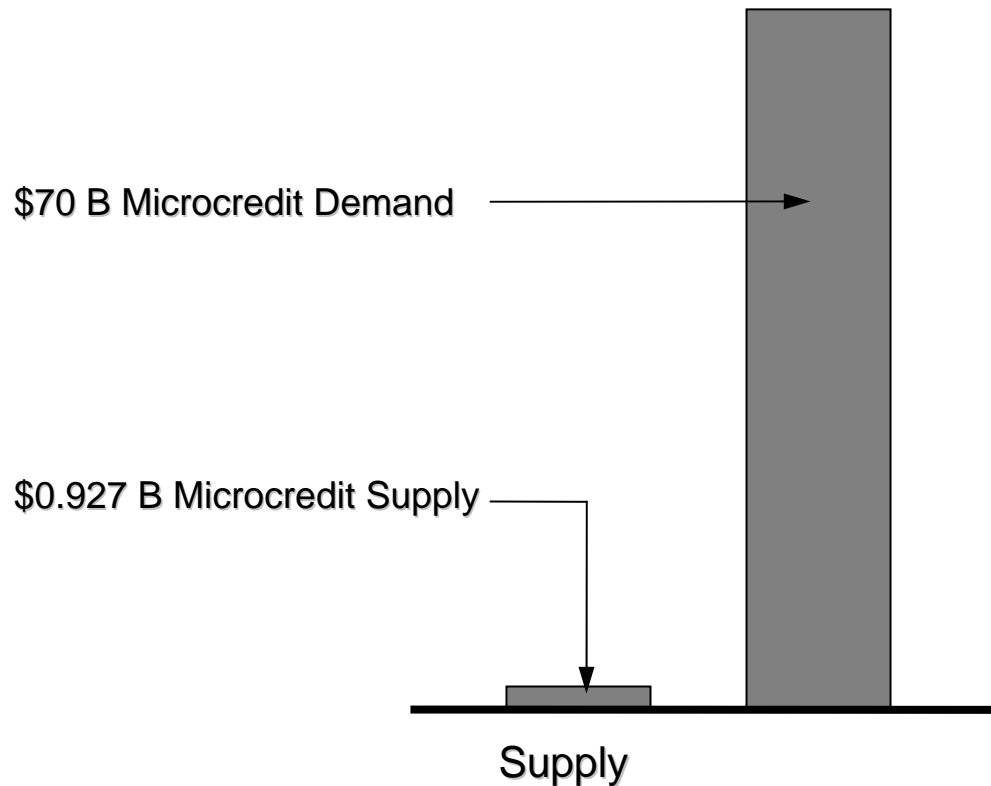

## Indian Microcredit Supply & Demand

*Invest India Savings and Income Survey, 2006*

# Ecosystem: Stakeholders

## Financial Institutions

- Banks
- VCs
- Apex

## Intermediaries

- MFIs
- Accelerators
- Consultants
- NGOs

Borrowers

## Policy Makers

- Regulators
- Trade Groups
- Researchers

## Technology Providers

- Banking Systems
- Hardware
- Communications

# Ecosystem: Supply & Demand

\$0.9B Supply

\$100B Demand

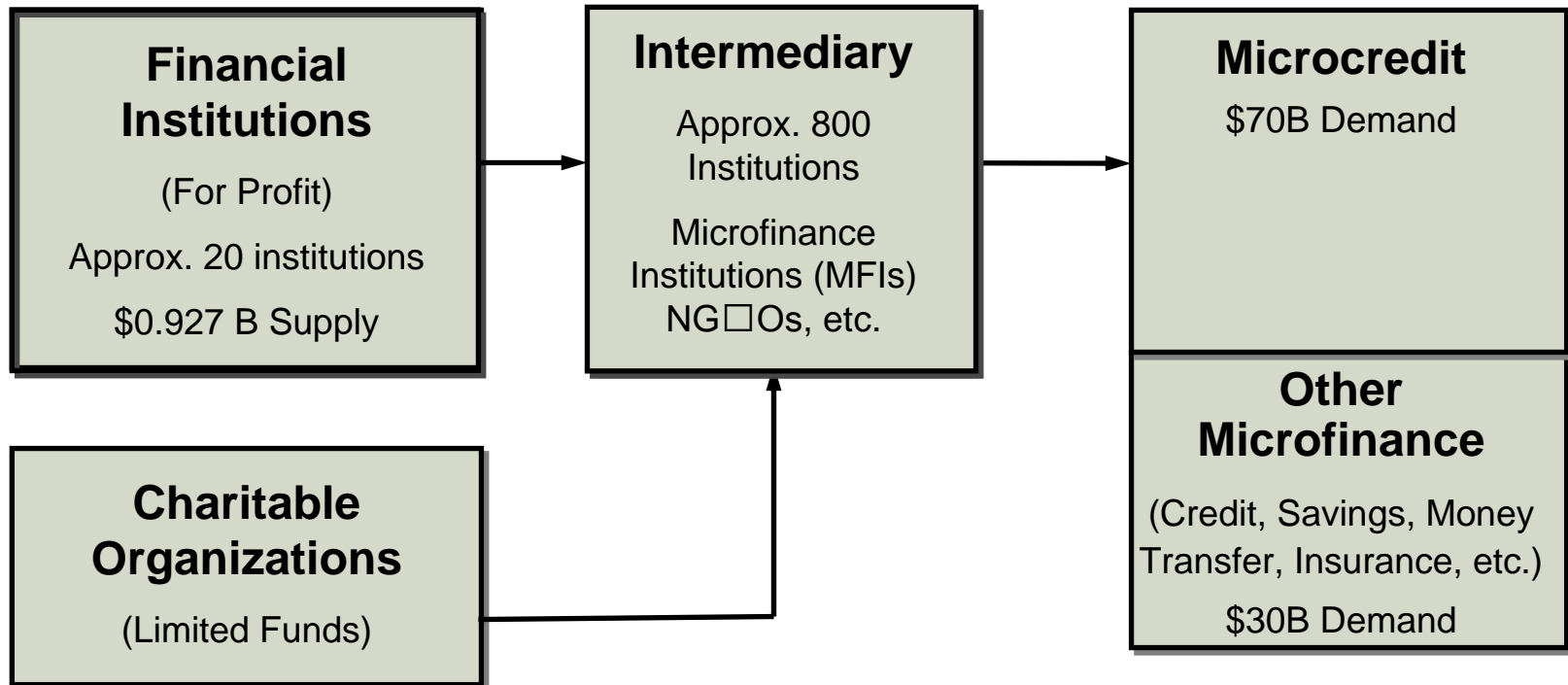

# Ecosystem: Process & Flow

## Flow of Funds

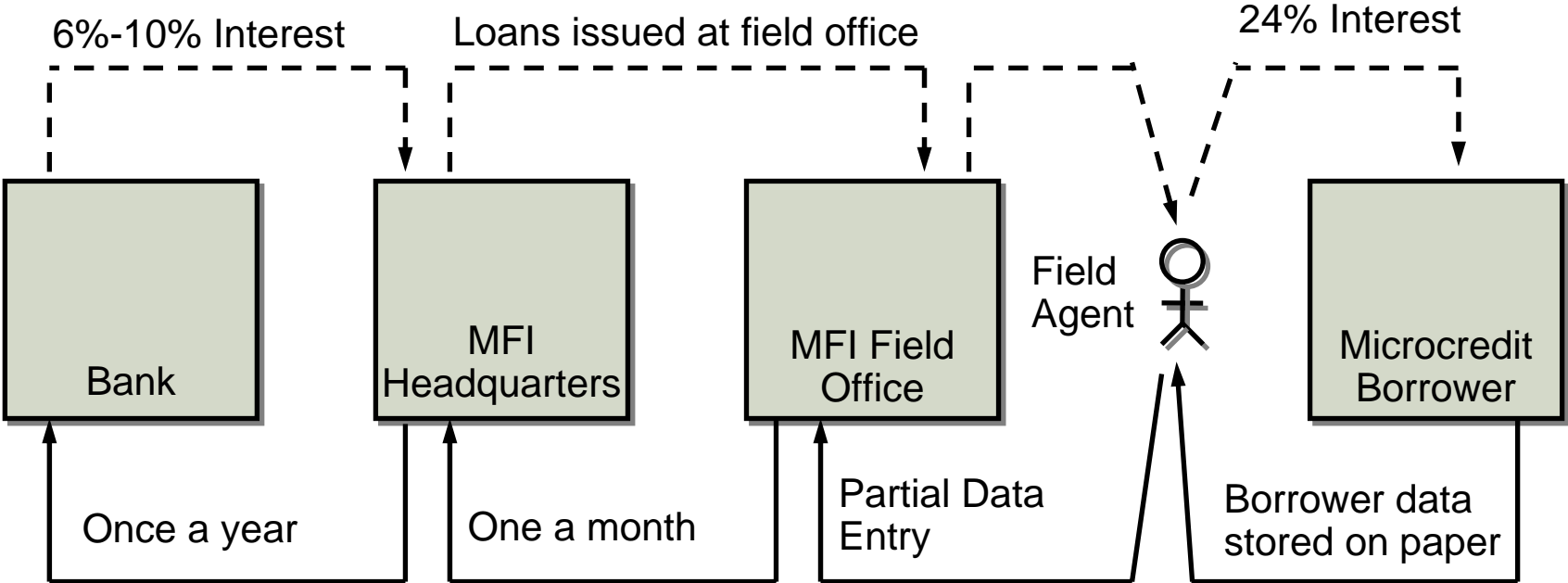

## Flow of Information



# End-to-end Technology Solution

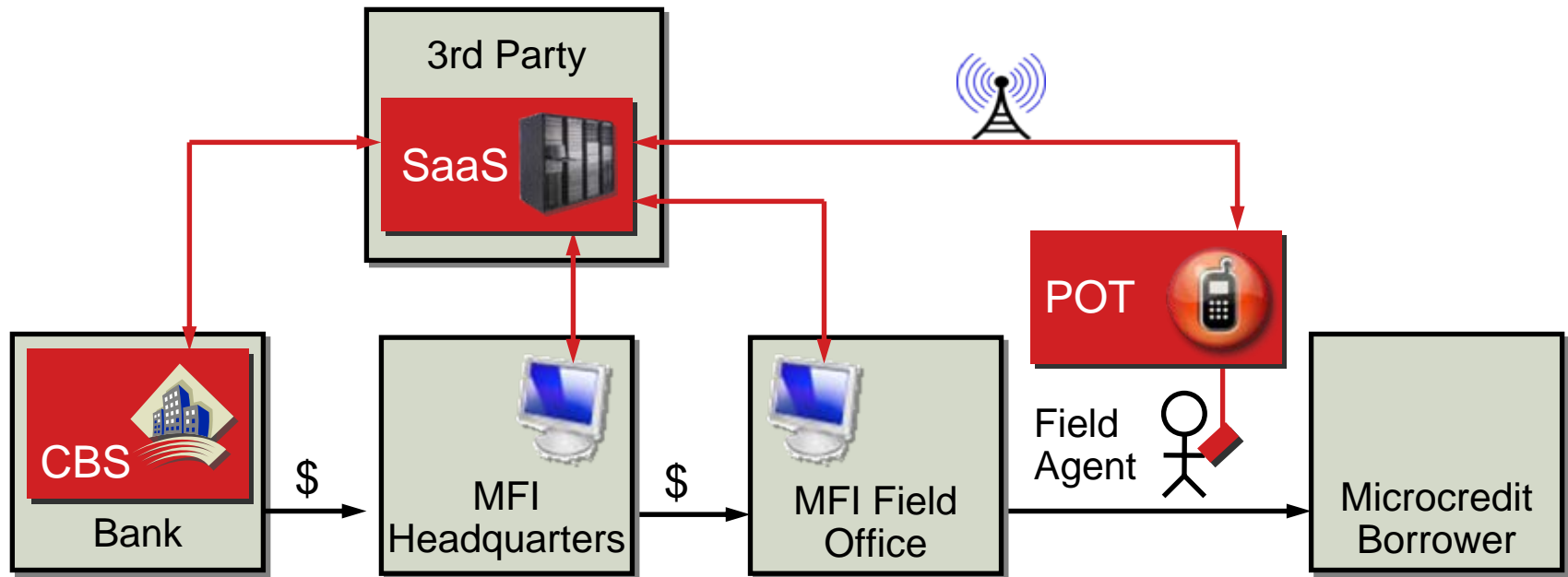

## Core Banking Solution

- Operated by bank
- Maintains real-time borrower account data

## Software as a Service

- Operated by 3rd party
- Data management
- Serves apps & data

## Point of Transaction

- Operated by field agent
- Mobile device
- Records data and authenticates

# Expansion: Secondary markets

- Savings
- Health Insurance
- Life Insurance
- Weather Insurance
- Crop Insurance
- Housing Loans
- Education Loans
- Wedding/Festival Loans
- Remittances
- Pension/Social Security Distribution
- Data Storage for a Credit Bureau

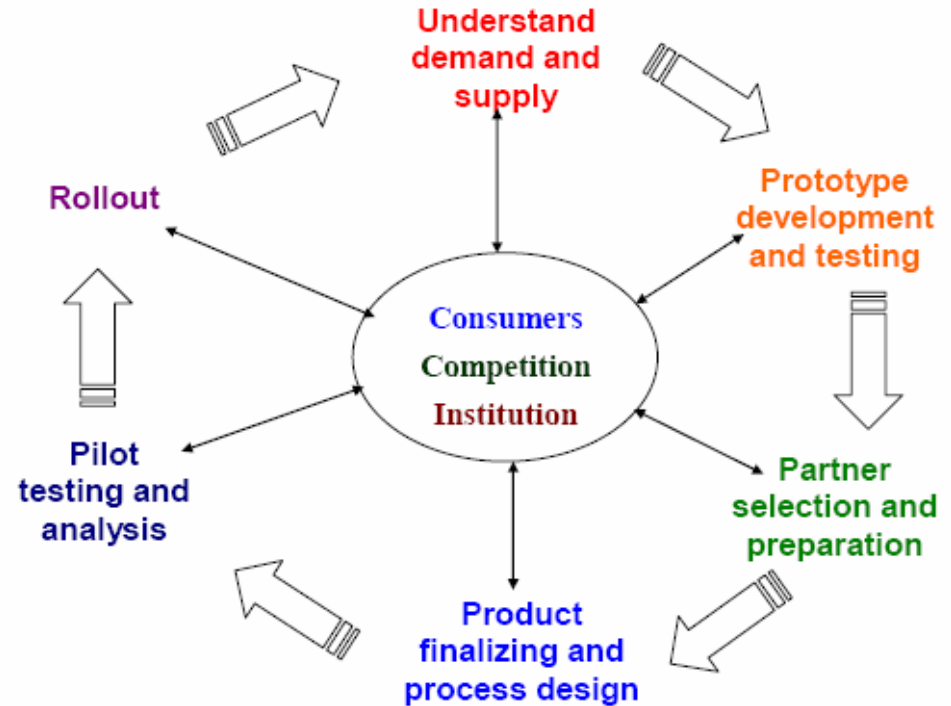

Figure: Product Development Process

Figure source: *Microinsurance NOTE 4 - Product Development—Making Microinsurance Products Successful. USAID.*

# Challenges

- Regulations
- Changing lending models
- Political (country) risk
- Mobile banking
- Lack of skilled manpower
- Technology infrastructure
- Education
- Language diversity

# Expanding Indian Microfinance Through Integrative Technology

Thank You!



Jill Fioravanti

Ann Le

Rajesh Sharma

Yumna Siddiqi